

LT-200 Controller

(Version V5.00)

Manual



(Please kindly read this manual carefully before use.)

Forword

Thanks for choosing our LT-200 Controller. Before installation and use, we strongly recommend you to read through this manual carefully. If device has been damaged during transport, please report it to your supplier immediately. Please don't take any action without contacting your supplier first.

After-sales Service

From the day you purchase our products within a year, if being used properly in accordance with the instruction, and quality problems occur, we provide free repair or replacement services except the following cases:

1. Any defects caused by wrong operations..
2. Any damages caused by unauthorized removal, maintenance, modifying circuit, incorrect connections and replacing chips.
3. Any damages due to transportation, vibration etc after the purchase.
4. Any damages caused by earthquake, fire, lightning strike, pollution and abnormal voltage.
5. Any damages caused by negligence, inappropriate storing at high temperature and humidity environment or near harmful chemicals.
6. Product has been updated

Safety Warnings

1. Please don't install this controller in lightening, intense magnetic and high-voltage fields.
2. To reduce the risk of component damage and fire caused by short circuit, make sure correct connection
3. Always be sure to mount this unit in an area that will allow proper ventilation to ensure a fitting temperature.
4. Check if the voltage and power adapter suit the controller & if anode or cathode definition is the same as the controller's.
5. Don't connect cables with power on, make sure a correct connection and no short circuit checked with instrument before power on.
6. Please don't attempt any repairs yourself; doing so will void your manufacture's warranty.

For update information, kindly please consult with your supplier.

Function Brief

LT-200 Controller is small but exquisite with powerful functions, it's easy to operate with LCD display interface and intelligent digital signal output, auto looking for address, the compatible LED lights don't need address coding, so easy to mount, this unit is widely used to control all LED lights based on built-in driving chips(without SCM), such as digital tube, pixel lamp, the led of the lights must be lined to the sequence of R,G,B,R,G,B,R,G,B…….

This unit supports universal DMX512/1990 standard com port, it can work with any device according with DMX512/1990 international protocol, there are fixed single color, color leap, color smooth, color flow, color chasing and so on, 30 color changing patterns in it, the changing modes and the control quantity can be preset at will, and the changing speed, running times of each changing mode can be configured independently and saved automatically.

I . Specifications:

Part No	LT-200 V5.00
Working Voltage	AC100-240V/DC12V
Power Consumption	≤1W
Control Method	TTL signal
Output Port	1(can be expanded to 8 channels)
Com Port	DMX512
Changing Pattern	30
Control quantity	8×1600 full color dots(pixels)
Dimension	L190×W120×H50(mm)

II. Basic Features

- 1、 Supports DMX512 port and remote control.
- 2、 30 color pattern options, each of the patterns' parameter can be configured separately.
- 3、 Auto running mode and fixed pattern available, running times can be configured.
- 4、 Auto store the parameter with power off protection.
- 5、 LOAD DEFAULT available.

III. Structure

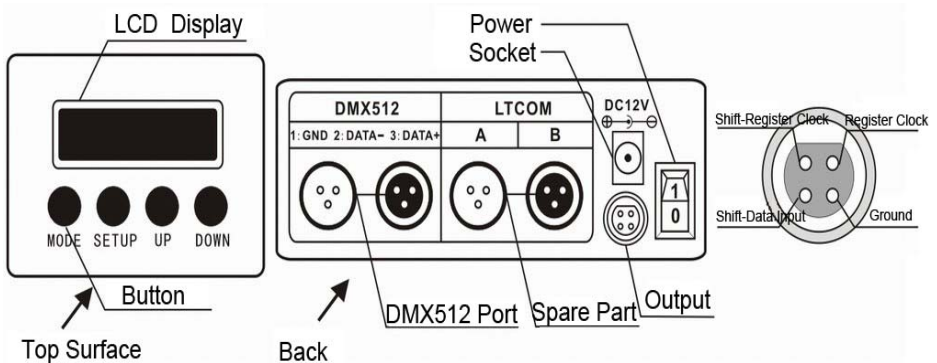

IV. Conjunction Diagram:

can control various compatible LED lights compatible with TTL(SPI) signal.

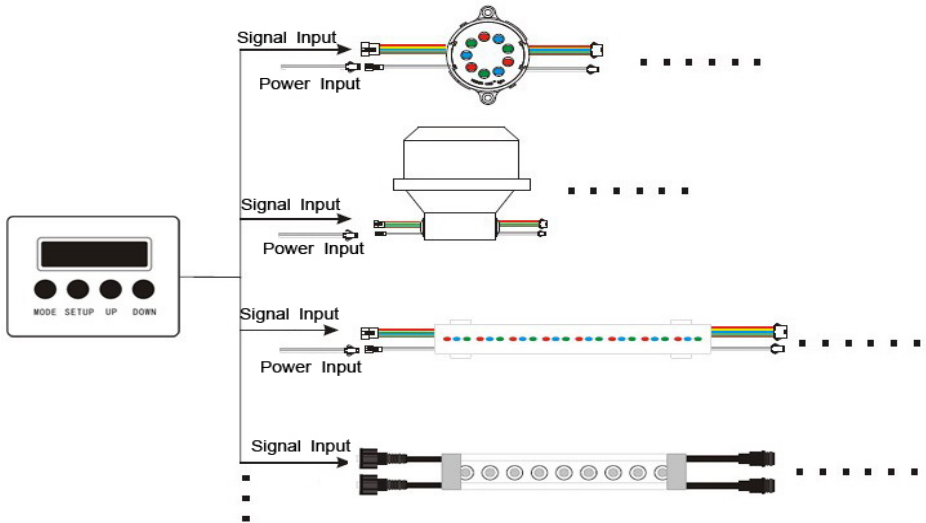

V Data Control Wire

Data wire	Fun
Black	Ground (GND)
Brown	Shift-data input(D)
Green	Shift-register clock(C)
Blue	Register clock(R)

VI Instruction

The controller has 4 functional buttons: MODE, SETUP, UP and DOWN.

1、 Press MODE or UP and DOWN to set in turn:

No.	Display	Description
1	BLACK	All off
2	STATIC RED	Static red
3	STATIC GREEN	Static green
4	STATIC BLUE	Static blue

5	STATIC YELLOW	Static yellow
6	STATIC PURPLE	Static purple
7	STATIC CYAN	Static cyan
8	STATIC WHITE	Static white
9	COLOR CHANGE	7 color leap change
10	COLOR FLOW	7 color black screen flow
11	COLOR SKIP	7 color black screen skip
12	COLOR STACK	7 color black screen brick
13	MIDSPLIT	7 color black screen midsplit
14	COLOR RECOIL	7 color recoil
15	COLOR COVER	7 color cover
16	FAST COVER	7 color twice cover
17	COME AND TO	7 color come & to scan 1
18	COLOR FLEX	7 color come & to scan 2
19	RACEHORSE	7 color racehorse
20	COLOR MEET	7 color meet
21	MIDSPLIT2	7 color midsplit
22	COLOR CHASE	7 color chasing
23	R & B CHASE	RB chasing
24	R & W CHASE	RW chasing
25	B & W CHASE	BW chasing
26	RGB CHASE	RGB left to right chasing
27	REVERSE CHASE	RGB right to left chasing
28	SMOOTH CHG1	7 color gradual change
29	SMOOTH CHG2	7 color fade & change
30	AUTO PROGRAM	Auto program
31	DMX512 MODE	DMX512 mode

 2、 Press SETUP: (no adjustable fun for 1–8)

No.	Display	Description	
		Max	Min
1	RUN SPEED	100	0
2	RUN TIMES	100	0
3	LOAD DEFAULT	Factory Set	
4	TUBE QTY 1 for 16 pixels	200	0
5	DMX512 ADDR	512	1

- 3、 UP: Up & re-set, press SETUP to confirm.
- 4、 DOWN: Down & re-set, press SETUP to confirm.
- 5、 Load Default: Each program are pre-set and saved by factory, Press LOAD DEFAULT can reload all default data. If run at AUTO PROGRAM to press LOAD DEFAULT, all data will be re-set to factory pre-set.
- 6、 RUN TIMES: Set the run times of program at AUTO PROGRAM. If it's "0", no this program at auto program mode.

VII. DMX512 Mode

At DMX512 Mode, you will receive 4 routes of signal, the starting address is adjusted through UP and DOWN (1–512), the address default is 1, each controller occupies 4 DMX512 addresses.

1. The 1st DMX512 data controls 29 PATTERNS,
2. The 2nd DMX512 data controls the speed.
3. The 3rd one is spare part of the system.
4. The 4th one is also spare part of the system.

VIII. Exception Handles:

Malfunction	Causation	Settle
No light	<ol style="list-style-type: none"> 1、 No power from plug. 2、 No signal output. 3、 First tube broken. 4、 At BLACK mode. 	<ol style="list-style-type: none"> 1、 Check the socket. 2、 Change the controller. 3、 Change the first light. 4、 Change the mode.
Front lights bright but some back lights not bright	<ol style="list-style-type: none"> 1、 Light qty incorrect set. 2、 Cable or connector is unstuck. 3、 Lights between bright and not bright broken 	<ol style="list-style-type: none"> 1、 Change light qty set. 2、 Fasten the cable, connector or change two front/back lights between bright and not bright. 3、 Change all lights between bright and not bright.
Not stable, can't be controlled	<ol style="list-style-type: none"> 1、 The controller broken. 2、 Strong interfering signal around. 3、 An overload wire, interfered by strike fire. 	<ol style="list-style-type: none"> 1、 Change the controller. 2、 Get rid of the interfering signal. 3、 Add wire and socket load or reduce connected lights, add more sockets.