

DMX512 decoder User Manual

1. Product introduction

SR-21XX Series DMX512 decoder are highly reliable, cost-effective decoder. There are two items which are constant-voltage and constant-current. The two categories have A/B versions for selection. A version is to select address by DIP switch. B version is to select address by button. Up to 5-channel decoder output can be used as RGBWY decoder, so do 5-channels.

2. Performance Parameter

2.1 SR-2102B and SR-2102BEA Constant Voltage

SR-2103FA and SR-2103EA Constant Voltage

SR-2105FA and SR-2105EA Constant Voltage

Input & output Voltage: 12-36V

Load Current: 3/4×5A and 3/4×8A, 3/4/5×5A and 3/4/5×8A

Max Load Power: 3/4×60-180W and 3/4×96-288W and 3/4/5×60-180W, 3/4/5×96-288W

Working Temperature: -20-+50℃

Load Type: 0.04-0.1W (regular LED)

Appearance Dimension: L178×W45×H19 mm and L178×W58×H29

2.2 SR-2112B and SR-2114B Constant Current

SR-2103FA3 and SR-2103FA7 Constant Current

SR-2105FA3 and SR-2105FA7 Constant Current

Input & output Voltage: 12-36V

Load Current: 3/4/5×350mA and 3/4/5×700mA

Max Load Power: 3/4/5×4.2-12.6 and 3/4/5×8.4-25.2

Working Temperature: -20-+50℃

Load Type: 1 W and 3 W (regular LED)

Appearance Dimension: L178×W45×H19mm

3. Features:

3.1 Standard DMX512 compliant control interface, enable to set the DMX address freely.

And show address Via digital numeric display.

3.2 Stand-alone mode and DMX512 decoder mode can be freely switched by buttons.

Under situation of stand-alone mode, it enables to adjust brightness per channel, also can entry the fading operation mode.

3.3 Three-channel/ four-channel/five-channel output selectable, Max. 5A or 8A per channel.

3.4 Three types available(CC,CV), suitable for different LED lamps.

3.5 To work with power repeater to expand output power unlimitedly.

4. Wiring diagram

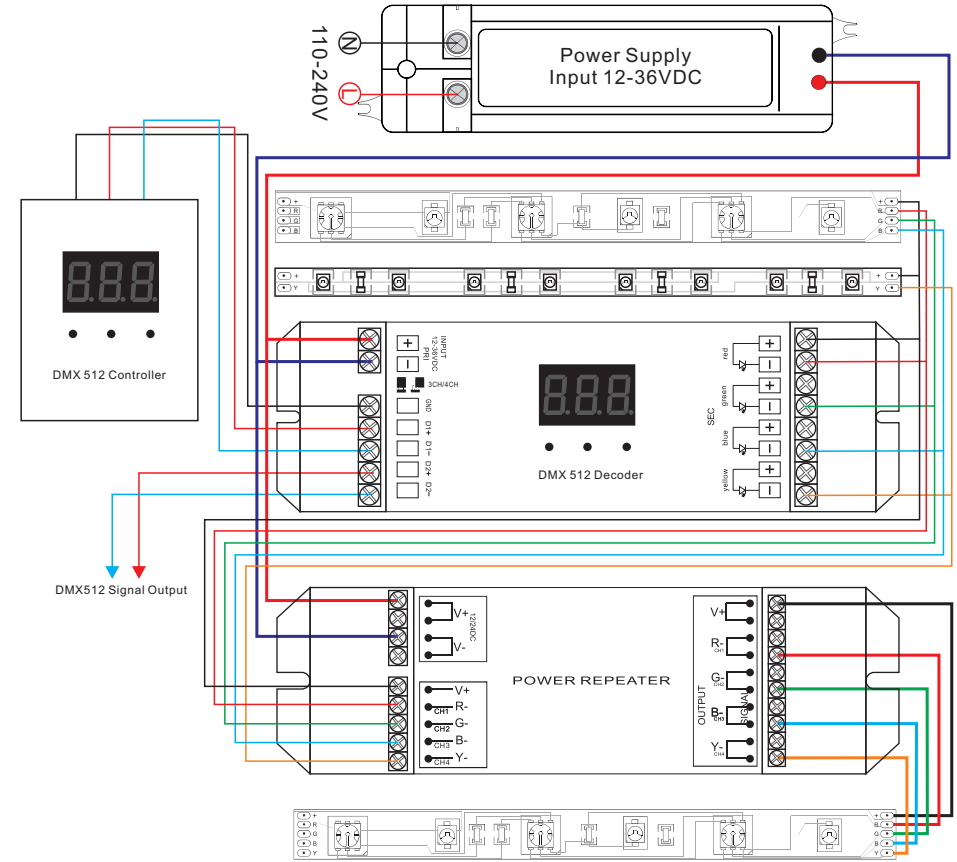

Power repeater connection diagram

5. Using instruction

5.1 Operation of SR-2102XX series:

Through buttons to set desired DMX512 address, 1 key is to set "hundreds" position, 2 is to set "ten" position, 3 is to set "a" bit.

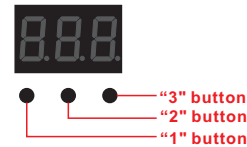

To open the connection of DMX512 controller, then it can work correctly.

5.2 Operation of SR-2103XX and SR-2105xx series:

The only difference between SR-2103XX and SR-2105xx series is: SR-2103XX max. Can be 4 channels, SR-2105xx series max. Can be 5CH.



5.2.1 Choose mode:

Press "1" and "2" key for 2 seconds, r,u digital display flashes, press "3" key choose 1 or 2 mode. If the board display ru1: stand-alone mode; ru2: slaver mode. press any button for 2 seconds to confirm the mode you need.



5.2.2 Choose Channel

Press "2" and "3" key for 2 seconds, c,h digital display flashes, press the first button to choose 3/4/5, 3 means total 3 channels, 4 means total 4 channels, 5 means total 5 channels. Press any button for 2 seconds to confirm the amount of channel.

5.2.3 Operation under DMX512 SLAVE mode

Under this mode, DMX512 device is just a standard of DMX512 SLAVE, it can connect DMX512 MASTER signal with DMX512 signal input port. Dimming lighting are operated by DMX512 master.

Through buttons to set desired DMX512 address, the digital numeric display the starting address. For example: the digital numeric display 001, it means this DMX slave include 001,002,003,004 addresses (under situation of 4 CH).

5.2.4 Operation under stand-alone mode

Under stand-alone mode, DMX512 device can be operated as a independent dimming controller, there is no need DMX512 signal. The function as follows:

If you choose ru1, after you press any button to confirm, the board will display P00.



5.2.5 P Moving mode

the first number after P, it can adjust moving mode, total 10 kinds of modes, from P0-P9, press P button, P will be flashing, then you can choose 0-9(10 modes). The second number after P, it can be used adjust moving speed. Total 10 levels of speed. Press P for 2 seconds, P button will be flashing, then you can choose number 0-9 to adjust speed. For example: P27: means P2 moving mode, speed level is 7.



5.2.6 C mode

Press the first button, the digital board will show C, it means DMX512 device enter into C mode.

Under this mode, it can adjust fixed colors independently, the fixed color have 8 kinds(C1-C8:red,orange,yellow,green, cyan, blue, purple). The second number after C stands for brightness of color, 8 levels brightness, 1 is the darkest, 8 is the brightest.



5.2.7 R mode

Press the first button, the digital board will show r, it means DMX512 device enter into r mode.

Under this mode, it can adjust brightness of the first channel from 0%-100%. Press r button for 2 seconds, r will be flashing, then you can choose brightness you want. 00:0%,FF:100%.



5.2.8 G mode

Press the first button, the digital board will show G, it means DMX512 device enter into G mode.

Under this mode, it can adjust brightness of second channel from 0%-100%. Press G button for 2 seconds, G will be flashing, then you can choose brightness you want. 00:0%,FF:100%.



5.2.9 B mode

Press the first button, the digital board will show B, it means DMX512 device enter into B mode.

Under this mode, it can adjust brightness of third channel from 0%-100%. Press B button for 2 seconds, B will be flashing, then you can choose brightness you want. 00:0%,FF:100%.



5.2.10 Y mode

Press the first button, the digital board will show Y, it means DMX512 device enter into Y mode.

Under this mode, it can adjust brightness of fourth channel from 0%-100%. Press Y button for 2 seconds, Y will be flashing, then you can choose brightness you want. 00:0%,FF:100%.



5.2.11 U mode

Press the first button, the digital board will show U, it means DMX512 device enter into U mode.

Under this mode, it can adjust brightness of fifth channel from 0%-100%. Press U button for 2 seconds, U will be flashing, then you can choose brightness you want. 00:0%,FF:100%.

Note: P, C, R, G, B, Y, U mode will be a loop.